



This Datasheet for the

## **IC660BBA106**

Block 115Vac/125Vdc Analog Current Source 6 Inputs

**<http://www.cimtecautomation.com/parts/p-14427-ic660bba106.aspx>**

Provides the wiring diagrams and installation guidelines for this GE Series 90-30 module.

For further information, please contact Cimtec Technical Support at

**1-866-599-6507**

**[sales@cimtecautomation.com](mailto:sales@cimtecautomation.com)**

# Current-source Analog Output Blocks

June 2002

GFK-0691D

## Description

Current Source Input Blocks are used to interface a controller to devices that provide 4mA to 20mA analog signals. Two Current-source Input Blocks are available:

- **115VAC/125VDC Current-source Analog Input Block** (IC66\*BBA106).
- **24/48VDC Current-source Analog Input Block** (IC66\*BBA026).

These blocks are identical except for the power supply.

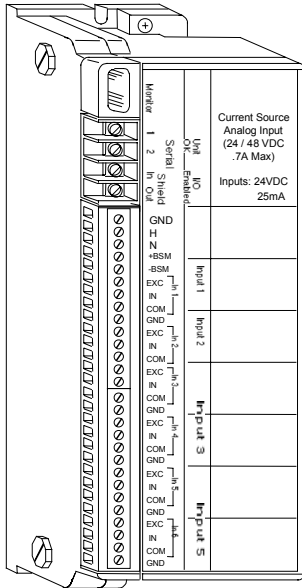

## Features

Block features include:

- Six 4-to-20 mA input circuits
- Isolated channels
- No user calibration required for operation
- Software configurable
- Advanced diagnostics
- Dedicated Bus Switching Module control

A Current Source Input block has six 4-to-20mA current inputs. Each input provides a 24 volt current loop power supply and is isolated from all other circuits within the block. The BSM circuitry is electrically common to Input 1, but isolated from the other inputs.

All circuits on the block support independent selection of linear scaling values. These values can be used to convert the internal values into engineering units suitable for the application.

Block diagnostics include:

- low and high alarm reporting
- overrange and underrange detection
- open wire detection
- internal fault reporting

A dedicated digital output is provided to drive a Bus Switching Module (version IC66\*BSM021 only).

## Specifications

### Catalog Numbers

115 VAC/125 VDC Current Source Analog Input Block	IC66*BBA106
Terminal Assembly	IC66*TBA106
Electronics Assembly	IC66*EBA106
24/48 VDC Current Source Analog Input Block	IC66*BBA026
Terminal Assembly	IC66*TBA026
Electronics Assembly	IC66*EBA026

### Block Specifications

Size (height x width x depth)	8.83" (22.44cm) x 3.56" (9.05cm) x 4.42" (11.23cm)		
Weight	4 lbs. (1.8 kg)		
LEDs (I/O Block)	Unit OK, I/O Enabled		
BSM Control	Switches one 24/48 VDC BSM (IC66*BSM021)		
Block to Block Isolation	1500V for one minute		
Group to Group Isolation	1500V RMS		
Heat Dissipation	12 Watts maximum		
Block Power (nominal);	115VAC	125VDC	24/4 VDC
Power supply voltage	98-132 VAC	105-145 VDC	18-56
Maximum current	250mA	140mA	700mA
Frequency/ripple	47-63 Hz	10% max. ripple	10% max. ripple
PS dropout time	1 cycle	10 ms min.	10ms min.

### Input Specifications

Input accuracy at 25° C	0.1% of full scale reading *		
Input resolution	1µA		
Input conversion time	16.6ms to 400ms (user selectable)		
Range	4mA to 20mA		
Overrange capacity	0mA to 25mA		
Input diagnostics	Underrange, Overrange, High Alarm, Low Alarm, Open Wire		
Channel to channel isolation	1500V RMS		
Thermal drift (from 25°C)	70 PPM per degree C typical		
Input Impedance	100 Ohms +/-5%		
Normal Mode Rejection	-45dB at 50, 60Hz		

### Input Excitation Characteristics

Open circuit voltage	24VDC
Short circuit current	<75mA
Loop impedance	1000 Ohms maximum (0mA to 20mA), 800 Ohms maximum (20mA to 25mA)

### Environmental Specifications

Operating temperature	0° C to +60° C (+32° to +140° F)
Storage temperature	-40° to +100° C (-40° to +212° F)
Humidity	5% to 95% (non-condensing)
Vibration	5-10 Hz 0.2" (5.08mm) displacement, 10-200 Hz at 1G

Refer to GFK-0867 for product standards and general specifications.

\* In the presence of severe RF interference (IEC 801-3, 10 V/m), accuracy may be degraded to +/-0.25% of full scale reading.

# Current-source Analog Output Blocks

June 2002

GFK-0691D

## Using this Datasheet

This datasheet summarizes information about block installation, configuration, and diagnostics.

Your primary reference should be the *Discrete and Analog Blocks User's Manual*. It includes detailed instructions for block installation and configuration.

For additional information about systems and communications, including bus specifications, refer to the *I/O System and Communications Manual*.

## Compatibility

Current Source Input blocks require a phase B Hand-held Monitor (IC66\*HHM501H, version 4.5 or later) for configuration.

For an IC697 series PLC, the programming software must be version 3.0 or later. Bus controller IC697BEM731C or later is required.

For an IC600 series PLC, the CPU must be rev. 105 or later. For an IC600 series "Plus" PLC, rev. 110 or later is required. The programming software must be rel. 4.02 or later. These blocks are compatible with bus controllers IC66\*CCBB902 and 903. They are not compatible with bus controllers IC66\*CBB900 and 901.

For an IC550 series PLC, the CPU must be rev. 3.0 or later. The programming software must be rel. 2.01 or later.

If a Bus Switching Module will be attached directly to the block, it must be the 24/48 VDC version (IC66\*BSM021).

## Installation Instructions

Carefully inspect all shipping containers for damage. If any equipment is damaged, notify the delivery service immediately. Save the damaged shipping container for inspection by the delivery service. After unpacking the equipment, record all serial numbers. Save the shipping containers and packing material in case it is necessary to transport or ship any part of the system.

## Block Mounting

Genius I/O blocks are considered "open equipment" and therefore must be installed within a protective enclosure. They should be located in an area that is clean and free of airborne contaminants. There should be adequate cooling airflow.

The block can be mounted right side up, or upside down. Leave at least 2 inches of space between blocks. Mount the block by drilling two screw or bolt holes for 8-32 hardware. Position the block so that the notches in the upper and lower flanges line up with the mounting holes. Mount the block using 8-32 screws. Use star washers to provide ground integrity.

## Grounding

The block's mounting screws must not be used as the only means of grounding the block. Connect the green ground screw on the block to a reliable ground system using a short wire lead, minimum size AWG #12 (avg 3.3mm<sup>2</sup> in cross-section).

### Warning

**If mounting screws do not make good ground connection and the ground screw is not connected to a reliable ground, the block is not grounded. Electrical shock hazard exists. Death or personal injury may result.**

## Block Wiring

Do not overtorque the terminal screws. Recommended torque for all terminals is 6 in/lb (.678 N/M).

## Serial Bus Wiring

Terminals 1 to 4 are for the serial bus. These terminals accept one AWG #12 wire (avg 3.3mm<sup>2</sup> cross-section) or two AWG #14 wires (each avg 2.1mm<sup>2</sup> in cross-section). The minimum recommended wire size is AWG #22 (avg .36mm<sup>2</sup> in cross-section).

Terminals 1 - 4 can also accommodate spade or ring terminals up to 0.27 inch (6.85mm) wide with a minimum opening for a #6 screw, and up to 0.20 inch (5.1mm) depth from the screw center to the back barrier. Be sure unshielded wire ends are not longer than 2 inches (5 cm).

Using one of the cable types recommended in the *System and Communications User's Manual*, connect the serial bus to terminals 1- 4. (If the block will control a Bus Switching Module, see below instead.)

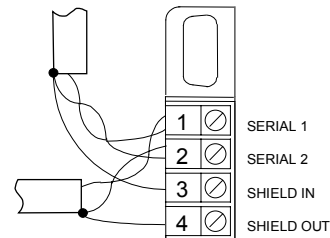

If the block is at either end of the bus, connect a terminating resistor of the appropriate type (see the System and Communications User's Manual for details) across its Serial 1 and Serial 2 terminals.

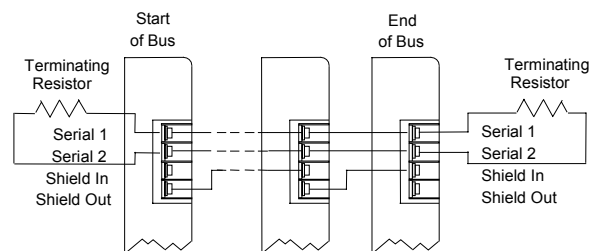

## Connecting a Bus Switching Module

If the block will control a Bus Switching Module, install the BSM at terminals 1-4, as shown on the next page. Connect the serial bus cables to the BSM as described in the *Bus Switching Module datasheet*. Wire either BSM pigtail wire to terminal 8 on the block, and the other to terminal 9.

# Current-source Analog Output Blocks

June 2002

GFK-0691D

## Field Wiring

Terminals 5 to 32 are for field devices. They take a single wire up to AWG #14 (avg 2.1mm<sup>2</sup> in cross-section). Minimum recommended size is AWG #20 (avg .54mm<sup>2</sup> in cross-section).

The ground (GND) terminal (5) is for block safety. It is connected to the block chassis, and to terminals 13, 20, 24, 28, and 32. These terminals, which are marked GND, are for shield termination, if desired.

Self-powered or externally-powered transmitters are wired differently from those powered by the block.

## Wiring for Block Power

For block power, connect an appropriate power source to terminals 6 and 7. For AC block power, connect the source to the H terminal and neutral to the N terminal. For DC block power, connect the source to the DC+ terminal and the return to the DC- terminal.

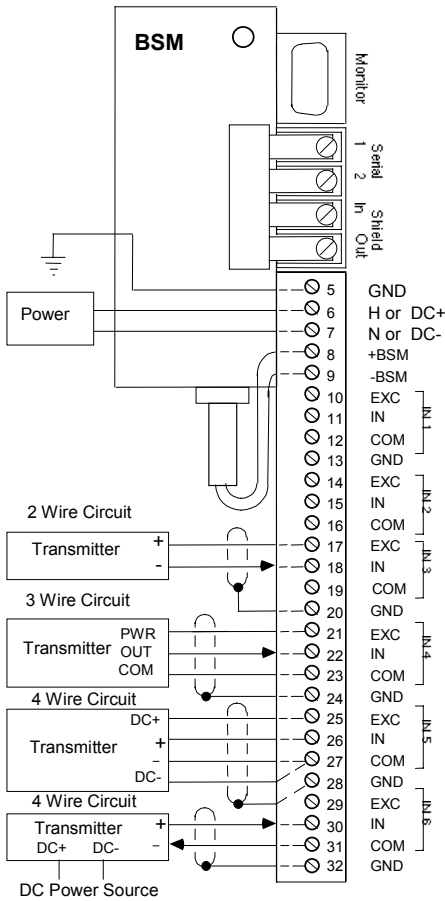

## Removing an Electronics Assembly

The block's Electronics Assembly can be replaced with a compatible model without removing field wiring or reconfiguring the block.

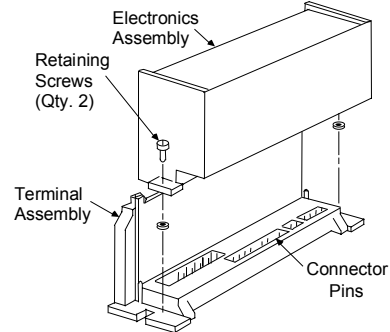

1. Unscrew the retaining screws at the top and bottom of the block.
2. Using a Block Puller (IC660BLM507), engage the tabs in the first vent slots. Move the tool to the center of the block and squeeze the handle.
3. Pull the Electronics Assembly upward.

### Warning

**If power is applied to the field terminals, power is also exposed on the connector pins at the base of the Terminal Assembly, and electrical shock hazard exists. Do not touch the connector pins! Death or injury may result.**

## Inserting an Electronics Assembly

1. Align the Electronics Assembly in the guides and push down firmly.

### Caution

**Do not exert excessive force; it may damage the block.**

2. If unusual resistance is met, remove the Electronics Assembly. If power is applied to the block, DO NOT TOUCH THE CONNECTOR PINS! Inspect the Terminal Assembly, connector receptacle, and connector edge board (on the Electronics Assembly). Be sure the keying matches. Remove any obstacles and reinsert the Electronics Assembly. Pay close attention to the alignment of the guide pins.
3. Secure the Electronics Assembly with the screws on the top and bottom of the Terminal Assembly.

## LEDs

The block's Unit OK and I/O Enabled LEDs show its operating status.

Unit OK	I/O Enabled	Meaning
ON	ON	Block functioning, CPU communicating
ON	OFF	Block functioning No CPU communications for 3 bus scans
ON	Blinking	Block functioning, Circuit forced
Blinking	ON	Circuit fault, CPU communicating
Blinking	OFF	Circuit fault No CPU communications for 3 bus scans
Alternate Blinking		Circuit fault, Circuit forced
Synchronous Blinking		No CPU communications - block number conflict
OFF	Blinking	Electronics/Terminal Assembly mismatch
OFF	OFF	No block power, or block faulty

# Current-source Analog Output Blocks

June 2002

GFK-0691D

## Block Operation

A Current-source Analog Input block has six independent inputs.

Input channels use voltage to frequency converters and counters to translate analog currents to a digital value. This value is converted by the block to engineering units before it is sent to the CPU. A diagram of an input circuit is shown below.

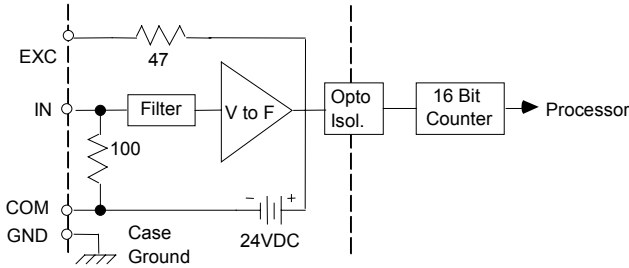

Each input circuit has a 24 volt current loop power supply, capable of providing 25mA of current. Each input is isolated from all other circuits on the block. Input accuracy is 0.1%. Input conversion time can be selected to provide the appropriate combination of noise rejection and input resolution. Conversion times are programmable from 16ms to 400ms. Resolution increases as the conversion time is lengthened. Input resolution is 1µA for 200ms conversion time.

Upper and lower alarm limits can be programmed for each input circuit. If either limit is exceeded, the block indicates a fault and sends a message to the Hand-held Monitor and CPU.

The following illustration shows the input excitation current derating versus temperature. The maximum excitation current per channel is 25mA.

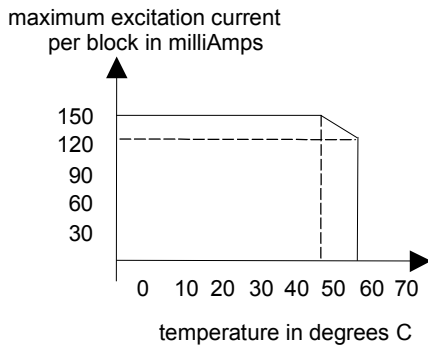

## Diagnostics

The block's advanced diagnostics provide the messages listed below. Fault messages can be cleared from the Hand-held Monitor or the CPU.

**Input Open Wire:** Input current is below 2mA.

**Input High Alarm:** Input exceeds high alarm level.

**Input Low Alarm:** Input exceeds low alarm level.

**Input Overrange:** Signal exceeds 25mA.

**Input Underrange:** Current is negative, or 0mA.

## Configuration

First, the block must be configured with a Hand-held Monitor to:

- Enter its Device Number (serial bus address).
- Enter its Reference Number (required only for IC600 and IC550 series PLCs only).

The rest of the features can be configured either using a Hand-held Monitor, or by sending a Write Configuration datagram to the block from the host.

**Note:** If a block is configured offline, it must be properly grounded and have a 75 Ohm resistor installed across its Serial 1 and Serial 2 terminals. See the *Discrete and Analog I/O Blocks User's Manual* for instructions.

Feature	Circuit /Block	Factory Setting	Selections
Device Number	Block	null	0 to 31 (must be selected)
Reference Address	Block	none	Depends on host CPU type
Baud Rate, Kbd	Block	153.6 std	153.6 std, 153.6 ext, 76.8, 38.4
Report Faults	Circuit	yes	yes/no
Channel active	Circuit	active	active/inactive
BSM Present	Block	no	yes/no
BSM Controller	Block	no	yes/no
CPU Redundancy	Block	none	none/standby
Input conversion time	Block	400ms	16 to 400ms
Input Scaling	Circuit	1µA per eng unit	+/-32767 eng units 0 to +25000µA
Low Alarm	Circuit	0	+/-32767 eng. units
High Alarm	Circuit	+25000	+/-32767 eng. units
Configuration Protection	Block	disabled	enabled, disabled